

Water Bath Shaker

- DRYING OVEN
- LABORATORY INCUBATOR
- MUFFLE FURNACE
- WATER DISTILLER
- WATER BATH & OIL BATH
- HEATING MANTLE
- STIRRER
- MIXER & SHAKER
- HEATING PLATE & SAND BATH
- DIGESTION APPARATUS & METAL BATH
- NITROGEN SAMPLE CONCENTRATOR
- CLEAN BENCH
- STERILIZER
- VACUUM PUMP
- FILTRATION
- GRINDER
- COLONY COUNTER
- DRYER
- CENTRIFUGE
- ELECTRIC FURNACE
- LIFTING TABLE
- LABORATORY CONSUMABLE

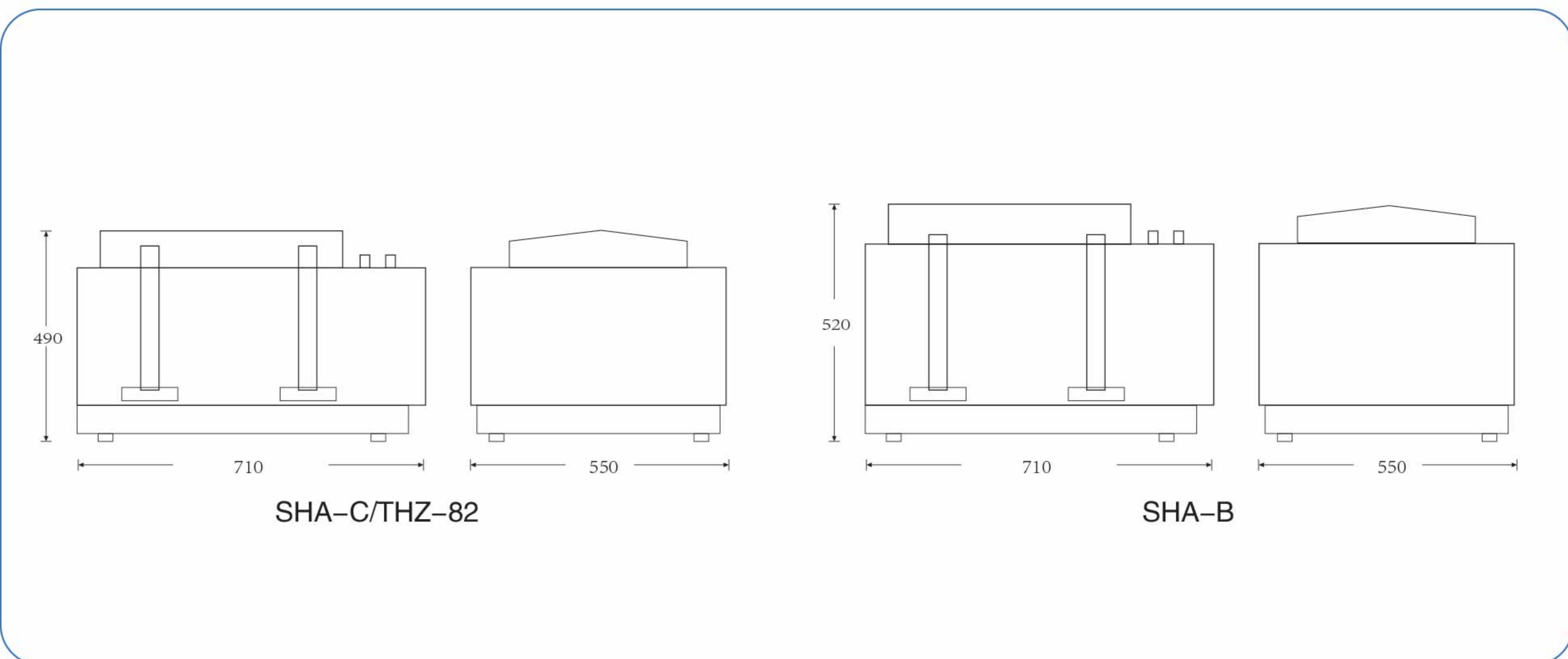

Dimension(mm)



DRYING OVEN

LABORATORY INCUBATOR

MUFFLE FURNACE

WATER DISTILLER

WATER BATH & OIL BATH

HEATING MANTLE

STIRRER

MIXER & SHAKER

HEATING PLATE & SAND BATH

DIGESTION APPARATUS & METAL BATH

NITROGEN SAMPLE CONCENTRATOR

CLEAN BENCH

STERILIZER

VACUUM PUMP

FILTRATION

GRINDER

COLONY COUNTER

DRYER

CENTRIFUGE

ELECTRIC FURNACE

LIFTING TABLE

LABORATORY CONSUMABLE

Water Bath Shaker is a biochemical apparatus by the combination of temperature controlled constant temperature water bath and shaker. It is an important and necessary laboratory equipment apply to plants, biology, microbiology, genetics, viruses, environmental protection, medicine and other scientific research, education and production department to do precision training preparation.

Scientific Research



Laboratory Study



College Experiment



Industrial Research

Characteristics:

- 1. LCD controller shows the measured value, set value and the setting time and the remaining time.
- 2. High-precision temperature control. resume operation automatically if power off unexpectedly.
- 3. Universal spring bottle rack which is suitable to multiple comparison test training preparation of biological samples
- 4. Variable speed, smooth and steady working speed, easy and safety to operate.
- 5. Inner chamber is made of stainless steel, well corrosion resistance.

Major Technical Parameters:

DRYING OVEN

LABORATORY
INCUBATOR

MUFFLE FURNACE

WATER DISTILLER

WATER BATH
& OIL BATH

HEATING MANTLE

STIRRER

MIXER & SHAKER

HEATING PLATE &
SAND BATH

DIGESTION APPARATUS
& METAL BATH

NITROGEN SAMPLE
CONCENTRATOR

CLEAN BENCH

STERILIZER

VACUUM PUMP

FILTRATION

GRINDER

COLONY COUNTER

DRYER

CENTRIFUGE

ELECTRIC FURNACE

LIFTING TABLE

LABORATORY
CONSUMABLE

Model	SHA-C	THZ-82	SHA-B
Operation Mode	Reciprocating Oscillation+thermostatic water bath	Circling Oscillation+thermostatic water bath	Reciprocating Oscillation+Circling Oscillation+thermostatic water bath
Controller type	LCD PID Intelligent controller		
Timing Range	0-120min		
Temp. Range	RT-99.9℃		
Temp.fluctuation	±1℃		
Temp.control Precision	±0.1℃		
Speed range(rpm)	Start-300	Start-300	Start-280
Voltage	110V/220V		
Heating Power	1500W		
Oscillation Amplitude(mm)	20		
Capacity	32L		
Material of water tank	Mirror Stainless steel		
Material of heater	Stainless steel heating pipe		
Material of Outer Shell	Cold rolling steel electrostatic spraying exterior		
Sensor	PT100		
Size of interior (L*W*H) (mm)	490*390*170		
Size of Exterior (L*W*H) (mm)	710*550*490	710*550*490	710*550*520