

Water Circulating All-Purpose Vacuum Pump

DRYING OVEN

LABORATORY INCUBATOR

MUFFLE FURNACE

WATER DISTILLER

WATER BATH & OIL BATH

HEATING MANTLE

STIRRER

MIXER & SHAKER

HEATING PLATE & SAND BATH

DIGESTION APPARATUS & METAL BATH

NITROGEN SAMPLE CONCENTRATOR

CLEAN BENCH

STERILIZER

VACUUM PUMP

FILTRATION

GRINDER

COLONY COUNTER

DRYER

CENTRIFUGE

ELECTRIC FURNACE

LIFTING TABLE

LABORATORY CONSUMABLE



Summary of use:

Based the lab area is small, on the basis of Water Circulating all-purpose vacuum pump, consulting to the Japanese desk pump, and it is improved and formed by once-molding housing and dwindling the volume. It has the characteristics such as small volume, light weight, beautiful outline and so on, it has the characteristics such as small volume, light weight, beautiful outline and so on, it is also facilitated outside circulated equipment, its degree of vacuum is stable.

Characteristics:

- Double meter and double tap are adopted, it can be used in single way or the way of parallel connection.
- Main frame is punch formed by the stainless armor plate, delicate and beautiful, sturdy and durable, the chamber body is made of engineering plastics.

Summary of use:

This product is a high sucking rate pump which is improved on the basis of SHB-B95 type, and also equipped with new type water separator, multiple tap jet, and the sucking rate is enlarged, it is the ideal vacuumize equipment in the lab. The main frame is made of stainless steel part, with the strong point such as corrosion resistance, stainless, prolonging the life span, non-polluting water resource and so on.

Characteristics:

- One-machine and single meter, multi-pipe operation, five sucking taps are equipped, it can be used in single way or the way of parallel connection.
- Corrosion resistance, non-polluting, stable operation, low noise, long life span.

Dimension(mm)

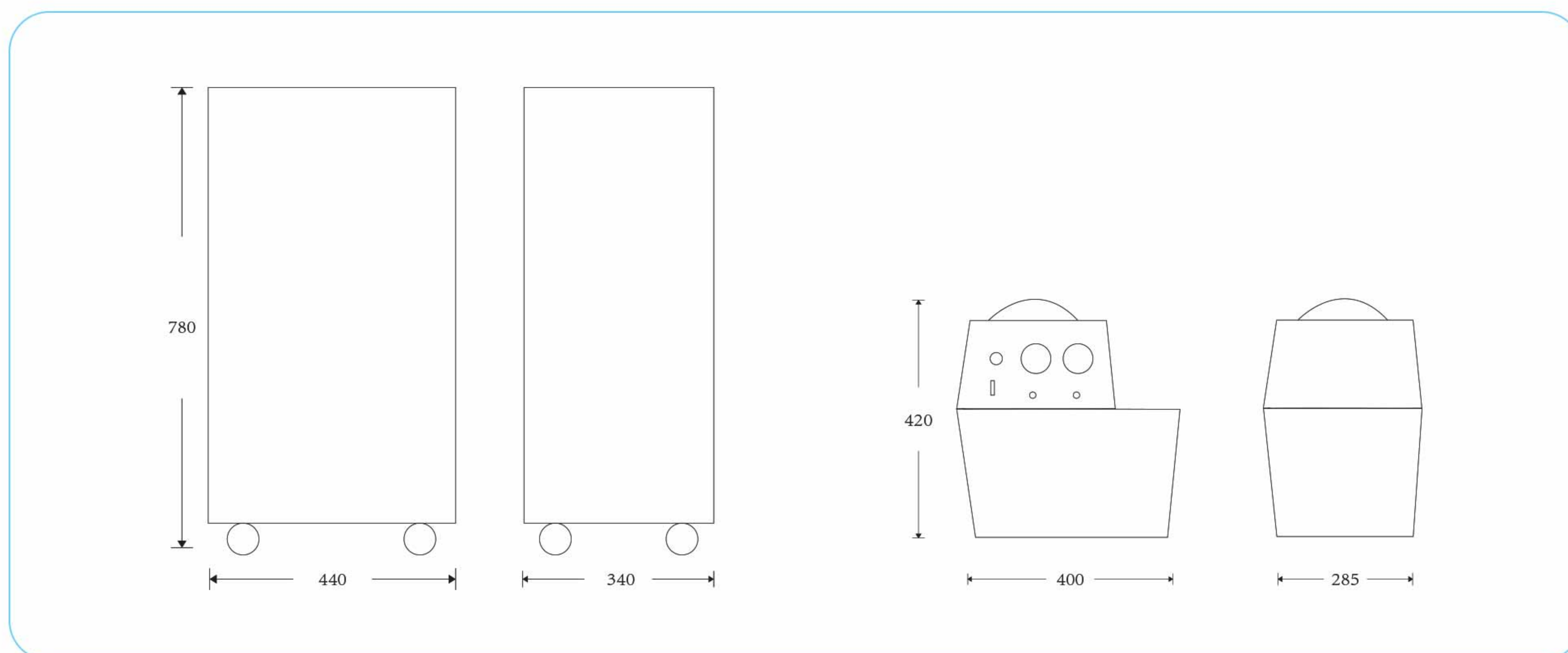

Major Technical Parameters:

Model & Specification	SHB-III A	SHB- B95A
Voltage	110/220V	
Power	180	370
The maximum vacuum degree	0.098Mpa	
Single tap sucking rate	10L/min	
Number of off-gas tap	2pc	5pc
Cubage of water tank	15L	57L
Overall dimension(L*W*H)(mm)	400*285*420	440*340*780
NW(KG)	9	32.5
GW(KG)	10	34