

# High Speed Universal Grinder

DRYING OVEN  
 LABORATORY INCUBATOR  
 MUFFLE FURNACE  
 WATER DISTILLER  
 WATER BATH & OIL BATH  
 HEATING MANTLE  
 STIRRER  
 MIXER & SHAKER  
 HEATING PLATE & SAND BATH  
 DIGESTION APPARATUS & METAL BATH  
 NITROGEN SAMPLE CONCENTRATOR  
 CLEAN BENCH  
 STERILIZER  
 VACUUM PUMP  
 FILTRATION  
**GRINDER**  
 COLONY COUNTER  
 DRYER  
 CENTRIFUGE  
 ELECTRIC FURNACE  
 LIFTING TABLE  
 LABORATORY CONSUMABLE

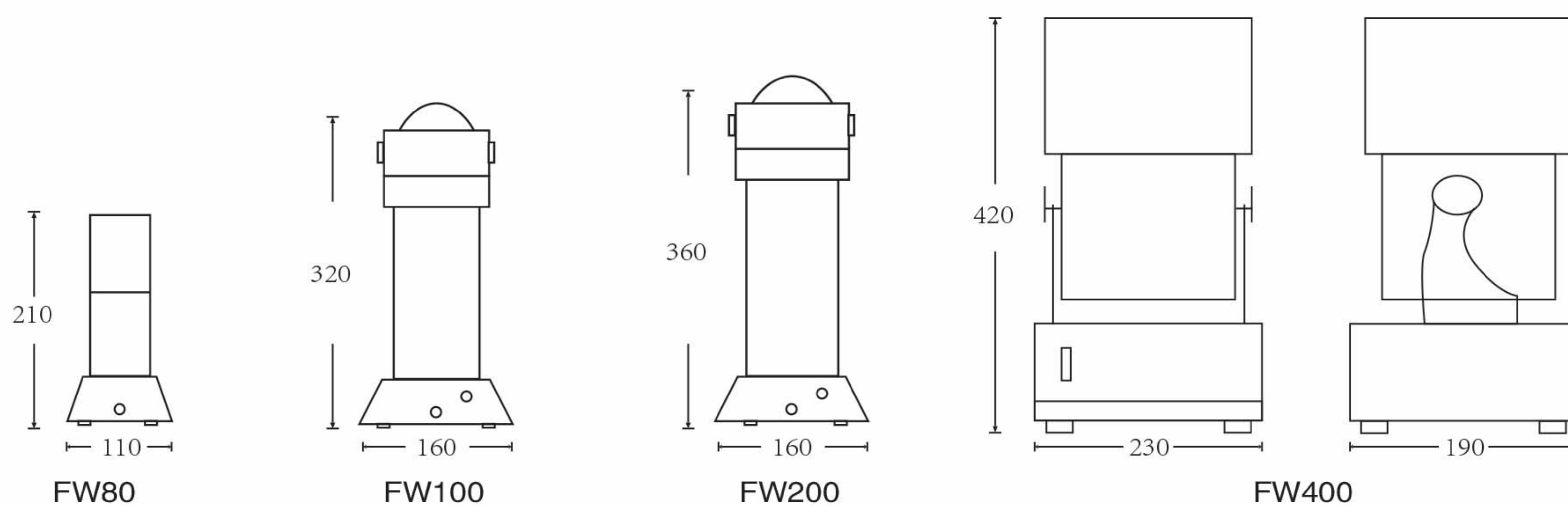

## Dimension(mm)



## Characteristics:

- The grinding room and cutter blade are made of imported stainless steel for the accuracy of analyzing treatment of experimental article.
- It has advantages of small cubage, high grinding efficiency, easy operation, beautiful shape and widely used.

DRYING OVEN  
 LABORATORY INCUBATOR  
 MUFFLE FURNACE  
 WATER DISTILLER  
 WATER BATH & OIL BATH  
 HEATING MANTLE  
 STIRRER  
 MIXER & SHAKER  
 HEATING PLATE & SAND BATH  
 DIGESTION APPARATUS & METAL BATH  
 NITROGEN SAMPLE CONCENTRATOR  
 CLEAN BENCH  
 STERILIZER  
 VACUUM PUMP  
**FILTRATION**  
 GRINDER  
 COLONY COUNTER  
 DRYER  
 CENTRIFUGE  
 ELECTRIC FURNACE  
 LIFTING TABLE  
 LABORATORY CONSUMABLE

## WIDELY APPLICABLE

It applies in grinding all kinds of food, soil, medicine, ore and mineral substance in the fields of industry, agriculture, industrial mining, medicine and health, colleges and universities, coal and geological etc.



### Major Technical Parameters:

Model	FW80	FW100	FW200	FW400A
Working voltage(v)	110/220v			
Power(w)	200	800	800	1000
Speed(r/min)	10000	26000	26000	26000
Size of grinding room (mm)(d*h)	Φ80*40	Φ100*40	Φ125*56	Φ150*80
Output quantity per time(≤g)	50	100	200	400
Fitness of grinding(mesh)	40-200			
Overall dimension(mm)(d*h)	Φ110*210	Φ160*320	Φ160*360	Φ230*190*420
NW (kg)	2.5	4.1	5	12.25
GW(kg)	2.7	4.7	5.6	13.25
Material	Mirror stainless steel			
Additional Function	High grinding efficiency			