

Electric Stirring Glass Water Bath

- DRYING OVEN
- LABORATORY INCUBATOR
- MUFFLE FURNACE
- WATER DISTILLER
- WATER BATH & OIL BATH**
- HEATING MANTLE
- STIRRER
- MIXER & SHAKER
- HEATING PLATE & SAND BATH
- DIGESTION APPARATUS & METAL BATH
- NITROGEN SAMPLE CONCENTRATOR
- CLEAN BENCH
- STERILIZER
- VACUUM PUMP
- FILTRATION
- GRINDER
- COLONY COUNTER
- DRYER
- CENTRIFUGE
- ELECTRIC FURNACE
- LIFTING TABLE
- LABORATORY CONSUMABLE

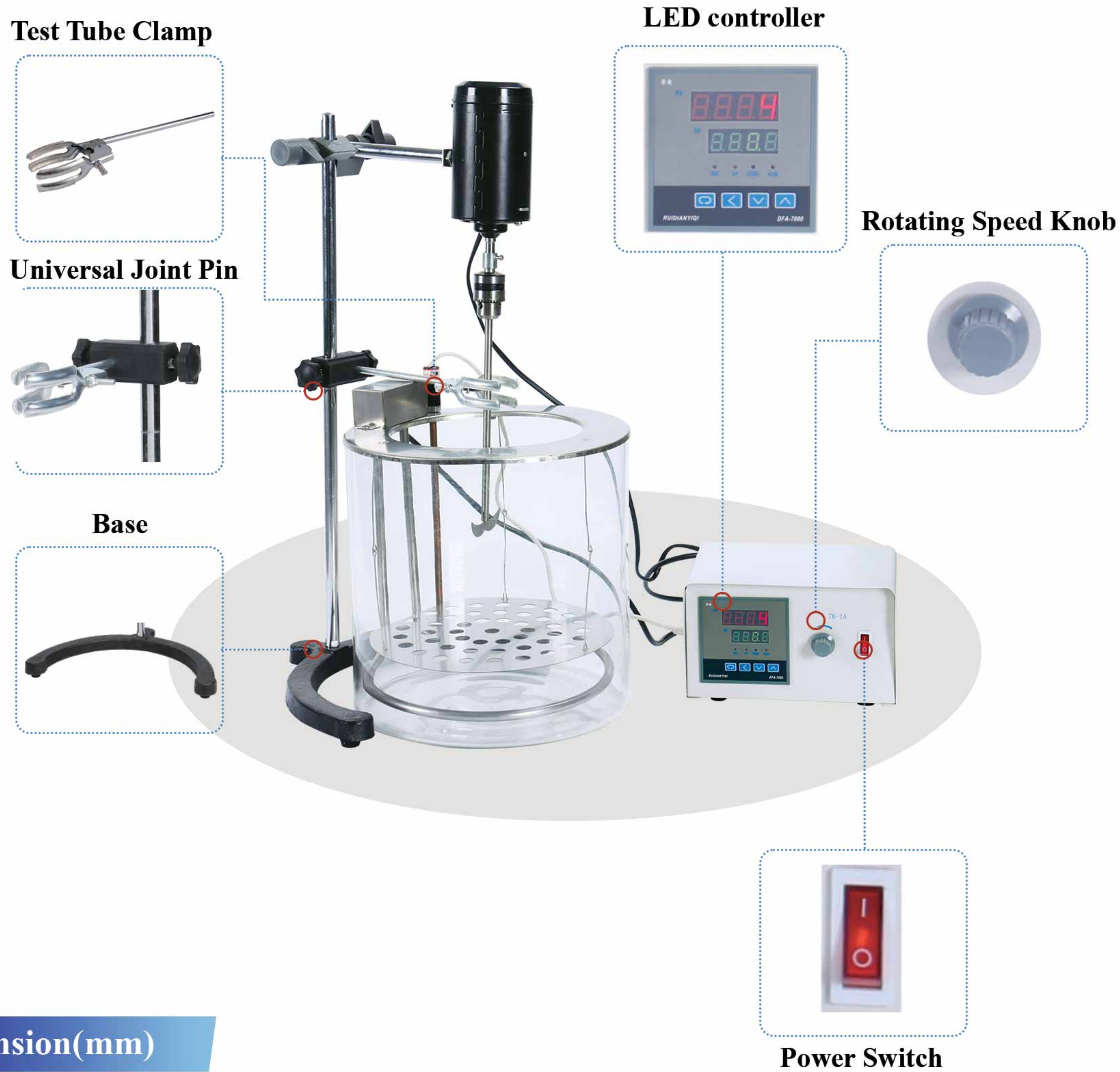

Dimension(mm)

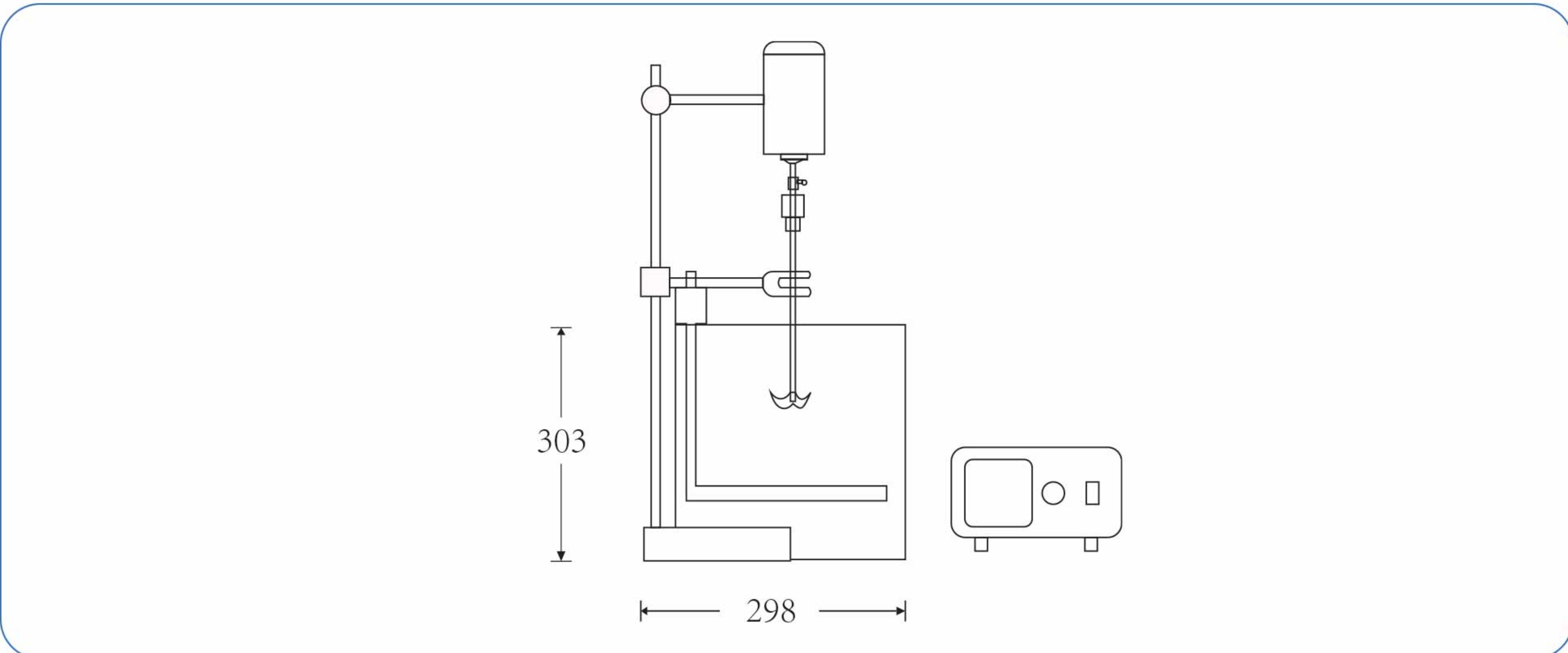

- DRYING OVEN
- LABORATORY INCUBATOR
- MUFFLE FURNACE
- WATER DISTILLER
- WATER BATH & OIL BATH**
- HEATING MANTLE
- STIRRER
- MIXER & SHAKER
- HEATING PLATE & SAND BATH
- DIGESTION APPARATUS & METAL BATH
- NITROGEN SAMPLE CONCENTRATOR
- CLEAN BENCH
- STERILIZER
- VACUUM PUMP
- FILTRATION
- GRINDER
- COLONY COUNTER
- DRYER
- CENTRIFUGE
- ELECTRIC FURNACE
- LIFTING TABLE
- LABORATORY CONSUMABLE

Electric stirring glass constant temperature water bath is used for water bath constant temperature heating and other temperature experiments



A must for college laboratories

Necessary for mining enterprises to experiment

Essential for medical research

Temperature Fluctuation Sheet:

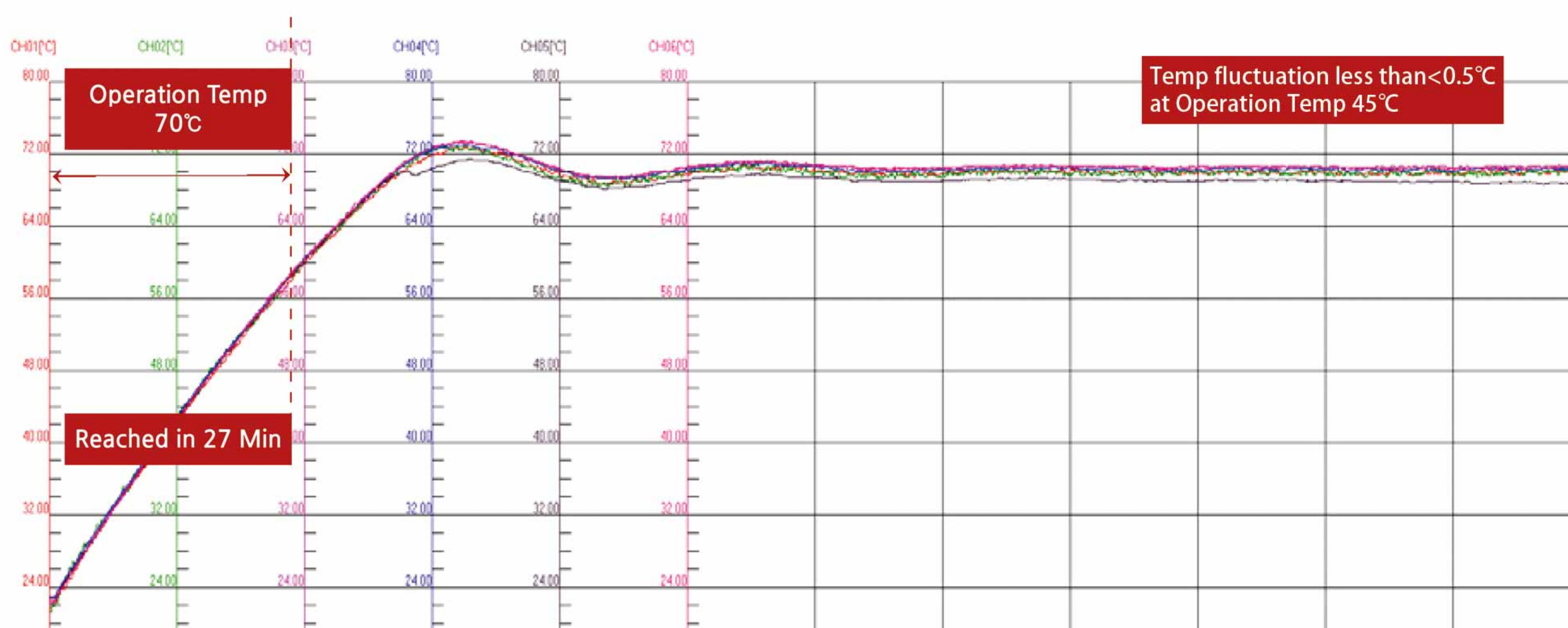

DRYING OVEN

Characteristics:

LABORATORY INCUBATOR

- Working area transparency allows the operator to observe internal experiments.

MUFFLE FURNACE

- Temperature digital display, automatic temperature control.

WATER DISTILLER

- With electric stirring, the water temperature rises evenly when heating.

WATER BATH & OIL BATH

Major Technical Parameters:

HEATING MANTLE

STIRRER

MIXER & SHAKER

HEATING PLATE & SAND BATH

DIGESTION APPARATUS & METAL BATH

NITROGEN SAMPLE CONCENTRATOR

CLEAN BENCH

STERILIZER

VACUUM PUMP

FILTRATION

GRINDER

COLONY COUNTER

DRYER

CENTRIFUGE

ELECTRIC FURNACE

LIFTING TABLE

LABORATORY CONSUMABLE

Model	76-1A
Voltage	110/220V
Range of temperature control (°C)	RT+5~ 100
Volatility (°C)	<0.5
Heating Power (kW)	1
String Power (W)	60
Rotating Speed	Start-3000RPM
Timing Range (min)	0~9999
Working room size (D * H) (mm)	205 * 240
Overall size (D * H) (mm)	298 * 303
Volume (L)	22L