

# Colony Counter

- DRYING OVEN
- LABORATORY INCUBATOR
- MUFFLE FURNACE
- WATER DISTILLER
- WATER BATH & OIL BATH
- HEATING MANTLE
- STIRRER
- MIXER & SHAKER
- HEATING PLATE & SAND BATH
- DIGESTION APPARATUS & METAL BATH
- NITROGEN SAMPLE CONCENTRATOR
- CLEAN BENCH
- STERILIZER
- VACUUM PUMP
- FILTRATION
- GRINDER
- COLONY COUNTER**
- DRYER
- CENTRIFUGE
- ELECTRIC FURNACE
- LIFTING TABLE
- LABORATORY CONSUMABLE

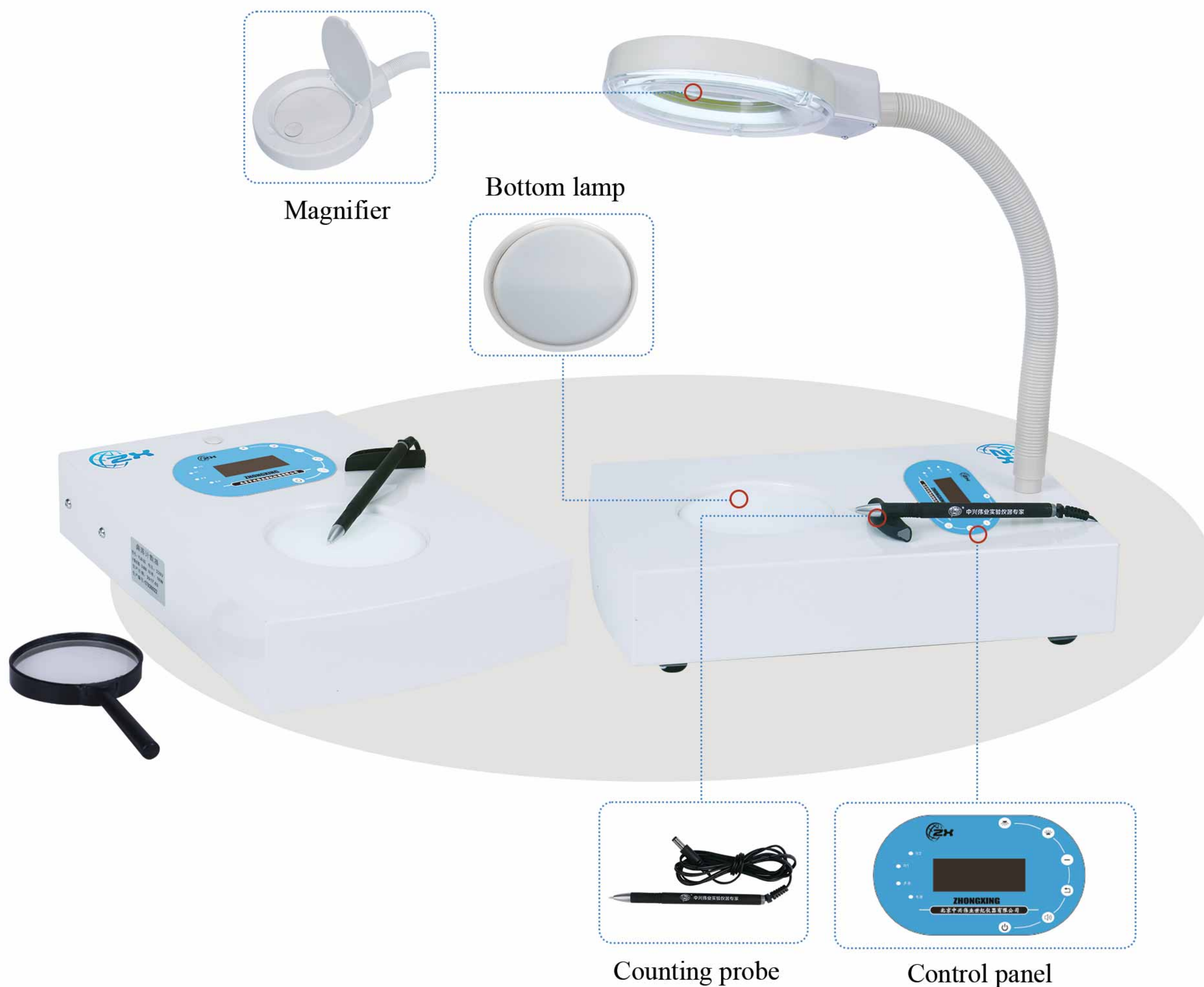

## Dimension(mm)

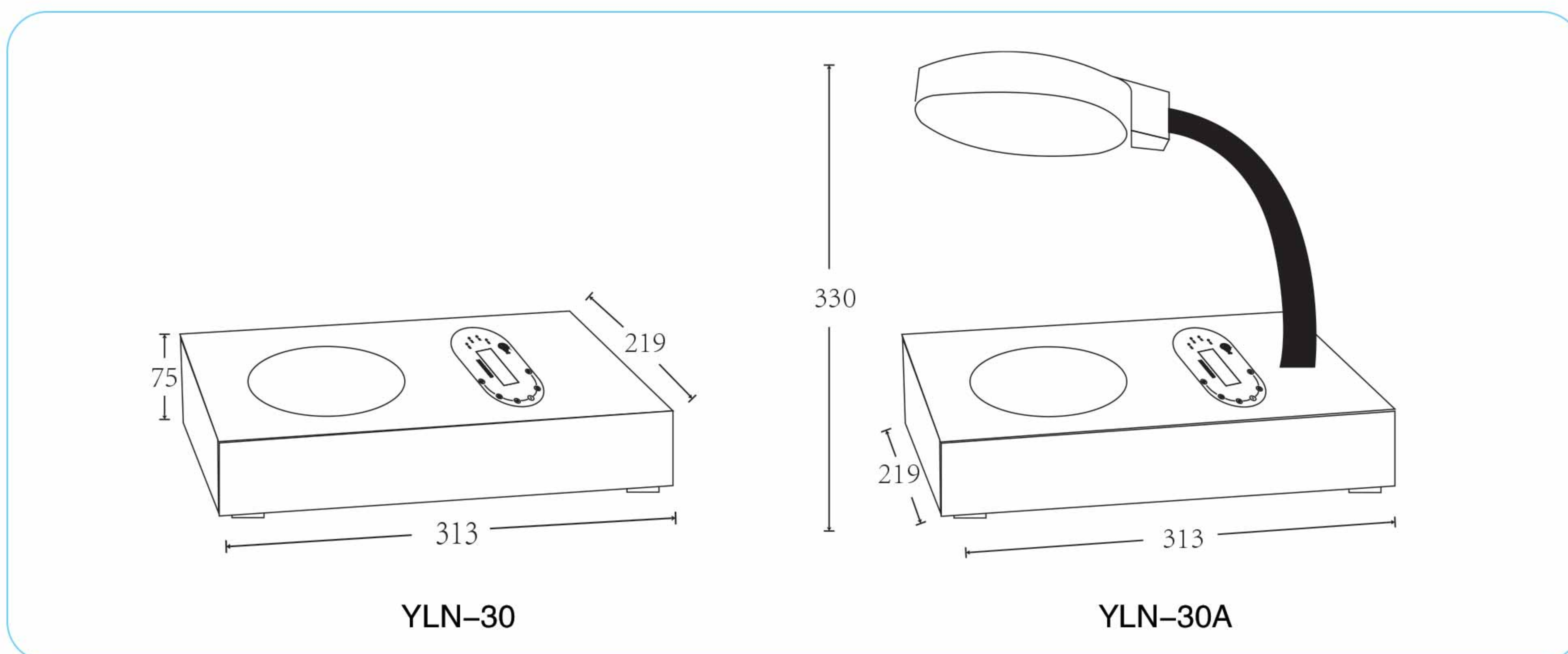



- DRYING OVEN
- LABORATORY INCUBATOR
- MUFFLE FURNACE
- WATER DISTILLER
- WATER BATH & OIL BATH
- HEATING MANTLE
- STIRRER
- MIXER & SHAKER
- HEATING PLATE & SAND BATH
- DIGESTION APPARATUS & METAL BATH
- NITROGEN SAMPLE CONCENTRATOR
- CLEAN BENCH
- STERILIZER
- VACUUM PUMP
- FILTRATION
- GRINDER
- COLONY COUNTER**
- DRYER
- CENTRIFUGE
- ELECTRIC FURNACE
- LIFTING TABLE
- LABORATORY CONSUMABLE

The colony counter that is produced by our company is a kind of digital display apparatus for inspecting bacteria automatically. It is made up of counter; probe, counting plate and the other parts, The counter is carefully designed with adopting CMOS molctron and LED display. It is clear and brightness, and it allows the user to quickly and accurately count bacteria colonies while using the special probe. Colony contrast is clear and easier to observe. This apparatus can lighten the laboring intensity of the laboratorian, improvethe work efficiency and working quality.



### Major Technical Parameters:

Model	YLN-30	YLN-30A
Description	Colony counter	Voice Count Off Counter
Technical parameter	Automatic, optics magnified 8X, transmission reflection illuminate, Counting scope 0-9999, power; 10W, the size of culture case; Φ90mm, Φ50	Automatomatic, optics magnified 5X, 10X, transmission reflection illuminate, Counting scope 0-9999 power; 20W the size of culture case; Φ90mm, Φ50. Count off with voice automatically.
Overall dimension (L*W*H)mm	219*313*75	219*313*330
NW (kg)	2.05	2.3
GW (kg)	2.4	2.84
Capacity of the Counter	0-999 pcs	
Power consumption of Lamp	20 W	
Magnification	3-9 Times	
Diameter of the counting plate	115mm	
Applicable petri dish	50-90mm	
Voltage	100/240V	