

# Clean Bench/Laminar Flow Cabinet

DRYING OVEN

LABORATORY INCUBATOR

MUFFLE FURNACE

WATER DISTILLER

WATER BATH & OIL BATH

HEATING MANTLE

STIRRER

MIXER & SHAKER

HEATING PLATE & SAND BATH

DIGESTION APPARATUS & METAL BATH

NITROGEN SAMPLE CONCENTRATOR

**CLEAN BENCH**

STERILIZER

VACUUM PUMP

FILTRATION

GRINDER

COLONY COUNTER

DRYER

CENTRIFUGE

ELECTRIC FURNACE

LIFTING TABLE

LABORATORY CONSUMABLE

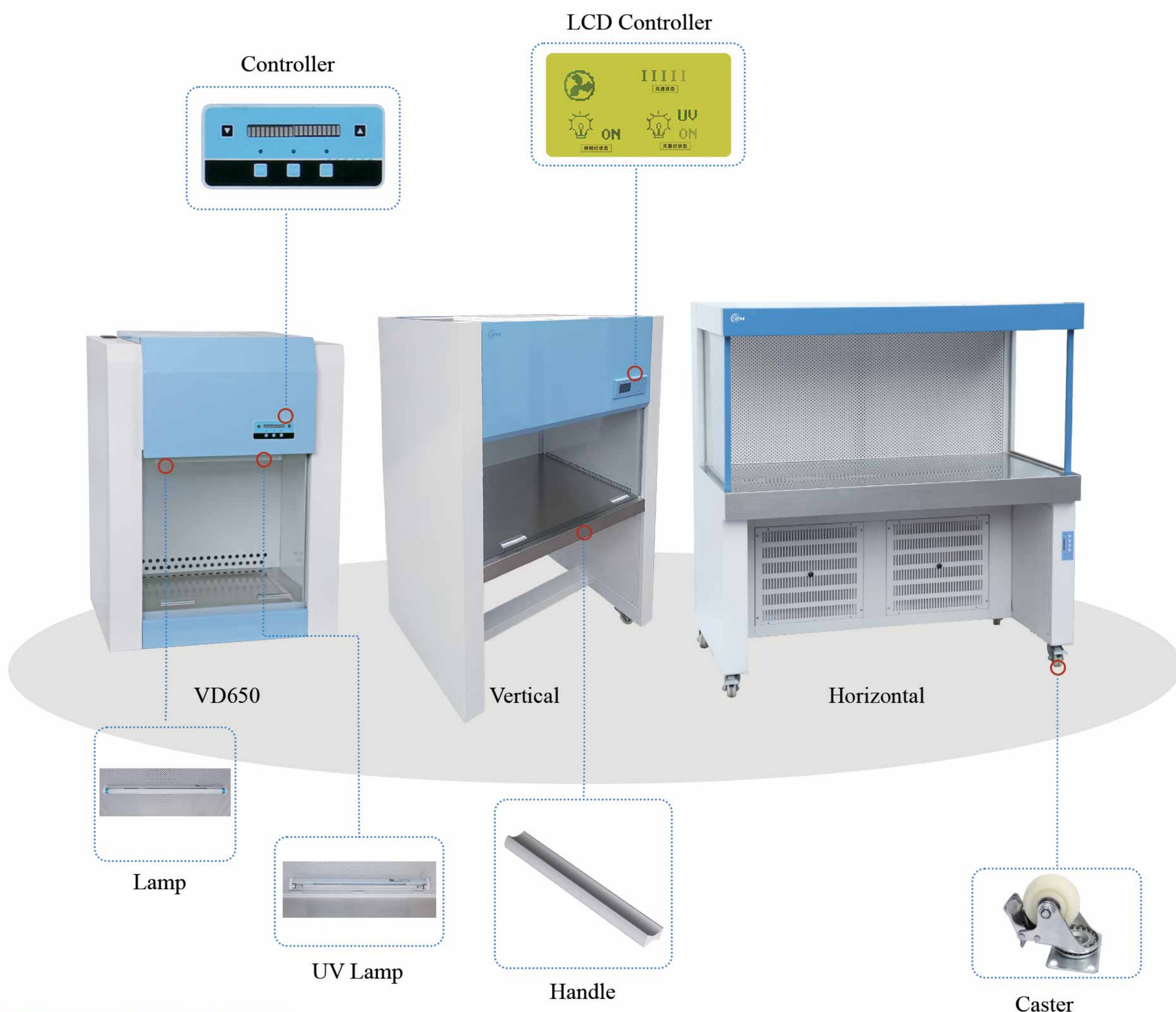

## Dimension(mm)

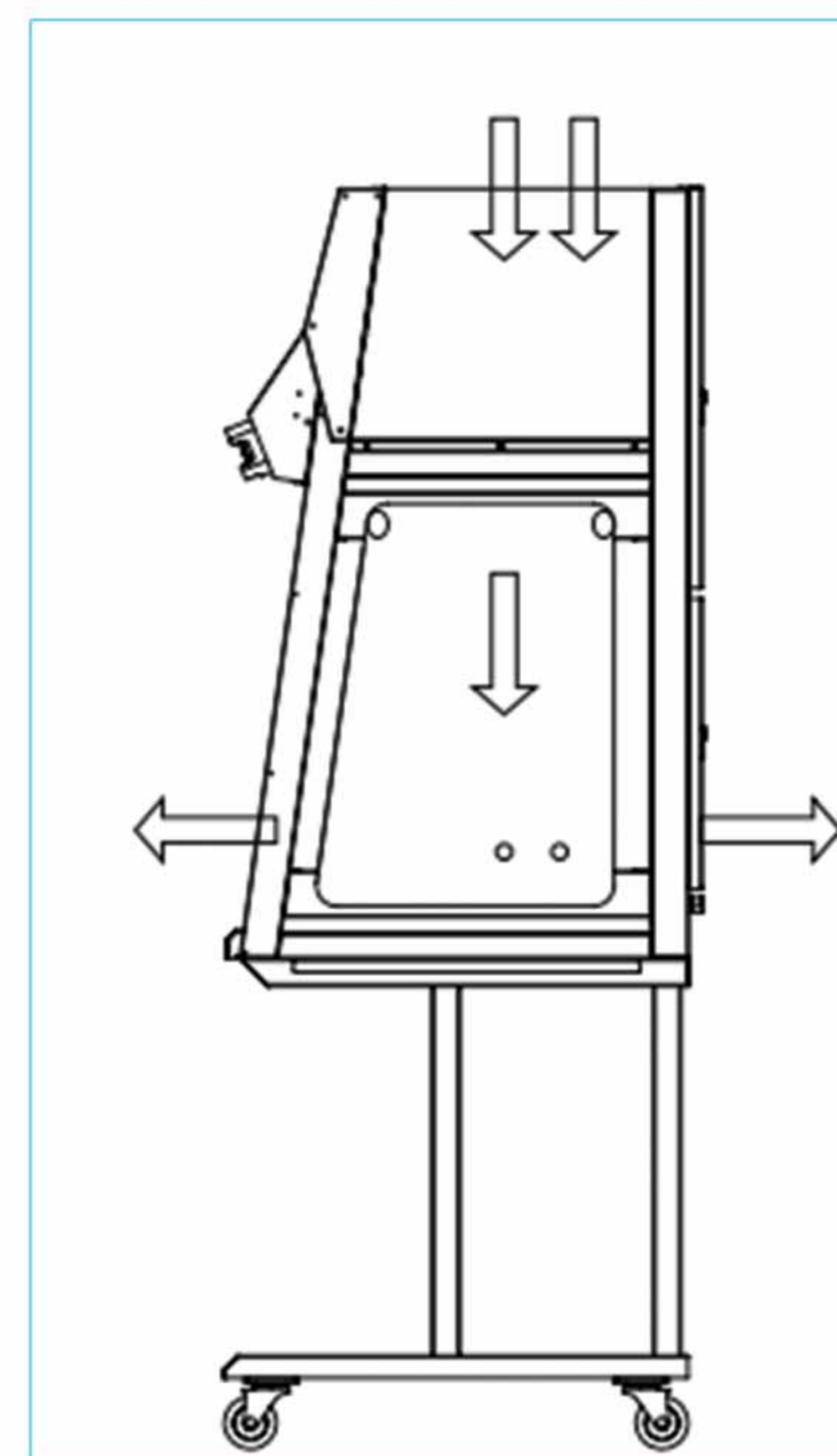
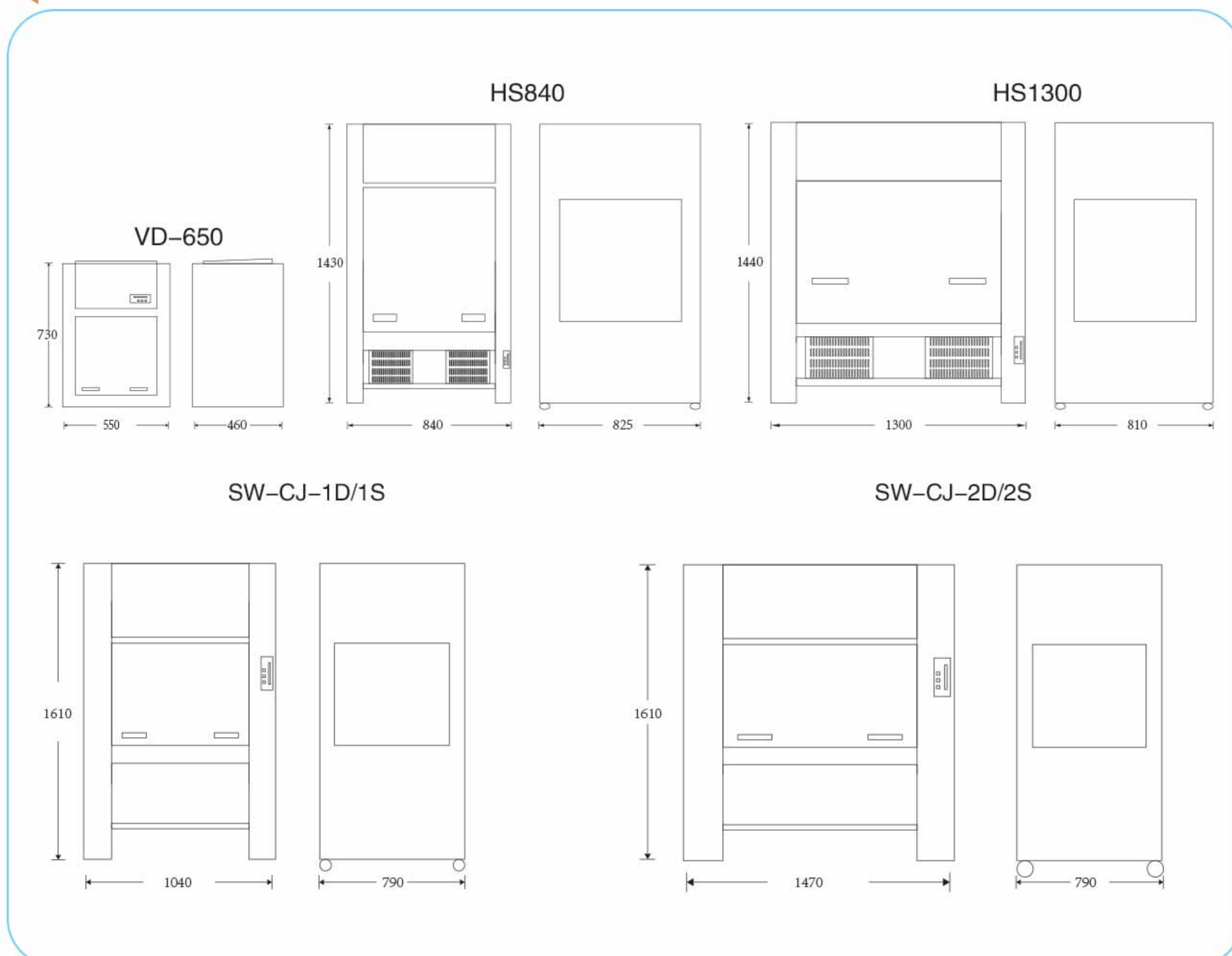

DRYING OVEN

LABORATORY INCUBATOR

MUFFLE FURNACE

WATER DISTILLER

WATER BATH & OIL BATH

HEATING MANTLE

STIRRER

MIXER & SHAKER

HEATING PLATE & SAND BATH

DIGESTION APPARATUS & METAL BATH

NITROGEN SAMPLE CONCENTRATOR

**CLEAN BENCH**

STERILIZER

VACUUM PUMP

FILTRATION

GRINDER

COLONY COUNTER

DRYER

CENTRIFUGE

ELECTRIC FURNACE

LIFTING TABLE

LABORATORY CONSUMABLE

Widely used in medicine, pharmacy and laboratories to get non - microorganisms, non - dust and clean conditions.

### ◆ Application fields:



**Biopharmaceutica**



**Drug hygiene**



**Microbiological testing**



**Plant culture**



**Microelectronics**



**Precision instrument**

### Characteristics:

- Simple and intuitive operation.
- Vertical air flow, work closed flat make air outside and harmful smell prevented.
- Adjustable air speed fan system to confirm air speed in ideal condition.
- Table surface made of high- quality stainless steel.

### Major Technical Parameters:

Model	VD-650	SW-CJ-1D	SW-CJ-1S	SW-CJ-2D	SW-CJ-2S	HS840	HS1300	
Application of number	AC220V50Hz	1 People in1 Side Type	1 People in2 Sides Type	2 Peoples in1 Side Type	2Peples in2 Sides Type	1 Peoplein1 Side Type	2 Peoples in 1 Side Type .	
Flow direction	Vertical					Horizontal		
Cleanliness Grade	100Grade @≥0.5μm ( 209E )							
Number of colony	≤0.5/ dish●hour ( φ 90mm culture plate)							
Average wind speed	0.2~0.6m/s	0.3 ~ 0.6 m/s ( adjustable )						
Noise	≤62 dB(A)							
Illuminance	≥300LX ( operation center )							
Power supply voltage	110/220V							
Controller type	LCD controller							
Timing range	1min~255min							
Maximum power	110W	400W		800W		400W	800W	
Vibration and semi-peak value	≤5μm	≤3μm		≤4μm		≤3μm		
Specification andquantityof(HEPA)S	480*280*50*1	820*600*50*1		610*610*50*2		820*600*50*1	610*610*50*2	
Quantity of Daylight & u.v lamp	Fluorescence 4W*1, UV 8Wx1	Fluorescence 20W*1, UV 20Wx1		Fluorescence 30W*1, UV 30W*1		Fluorescence 20W*1, UV 20W*1	Fuorescence 30W*1, UV 30W*1	
Size of working room (mm)	480*340*370	880*710*515	880*710*515	1310*710*515	1310*710*515	1310*710*515	1210*660*570	
Overall dimension of packing(mm)	550*460*730	1040*790*1610	1040*790*1610	1470*790*1610	1470*790*1610	840*825*1430	1300*810*1440	
Material	Mirror stainless steel							
Additional Function	Vertical air flow							
	Adopt adjustable air volume fan system							